

Rated Voltage (Vac)	380
Rated Power (w)	5500
Rated Torque (N.m)	35
Peak Torque (N.m)	87.5
Rated Speed (rpm)	1500
Peak Speed (rpm)	3000
Rated Current (Amp)	20.5
Peak Current (Amp)	51
Torque Const (N.m/Amp)	1.7
Back EMF Const (V/krpm)	113
Resistance (Ω)	0.2
Inductance (mH)	4.9
Inertia (kg*m ² *10 ⁻⁴)	73.84
Poles	10
Encoder type	23bit optical
IP rating	IP65
Mass (Kg)	30.9

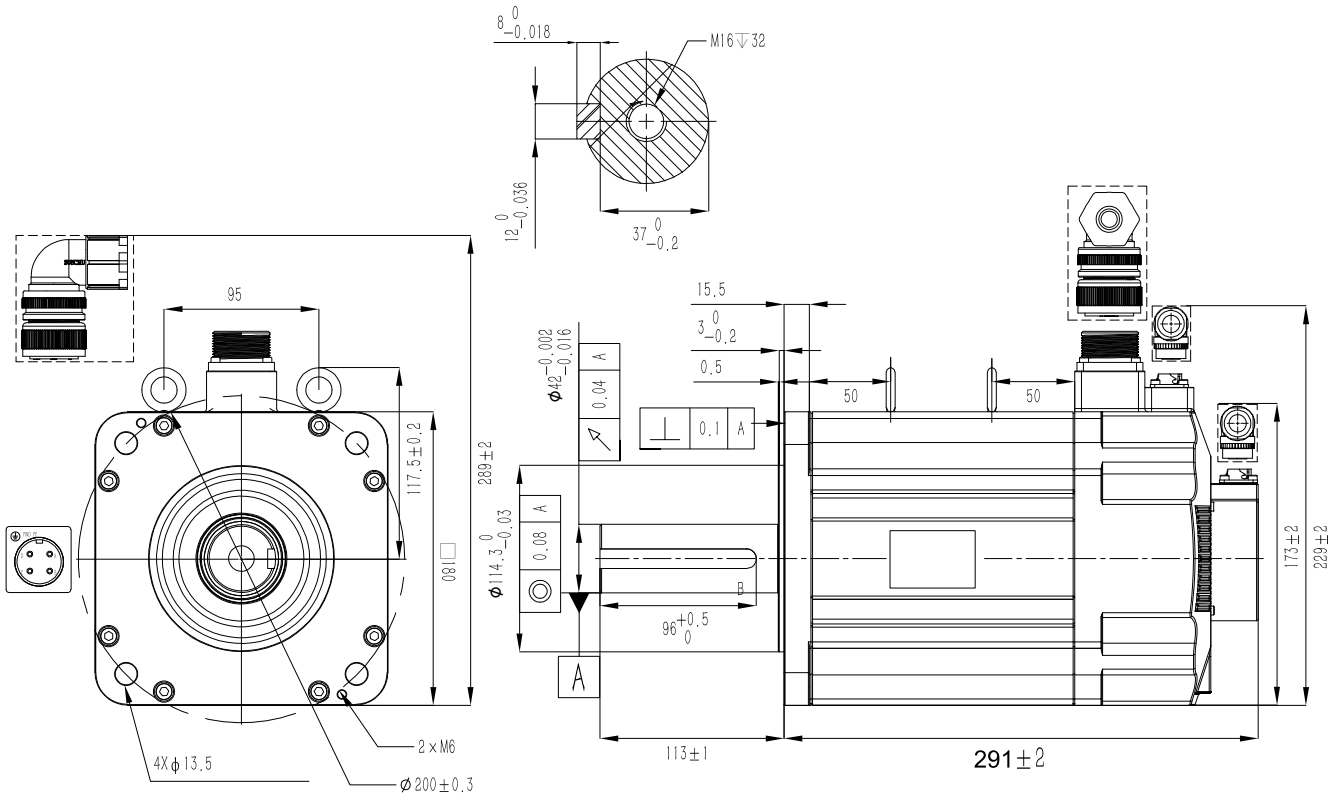

Power connector

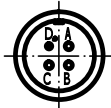

Wiring details of Power cable connector

Pos	A	B	C	D
Signal	U	V	W	PE
Color	red	yellow	blue	Yel/Gre

Encoder connector



Wiring details of encoder cable connector

Pos	1	2	3	4	5	6	7	8	9	10
Signal	/	5V	0V	SD+	SD-	E+	E-	/	/	PE
Color	/	red	black	blue	yellow	brown	white	/	/	shield

Torque(Nm)

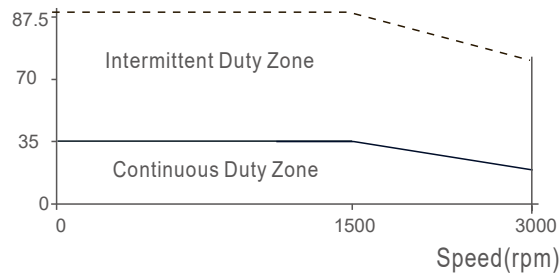

Brake connector



Brake connector

Pos	1	2
Signal	0V	24V
Color	/	/

GMTCNT

S2M180F5500BH

180mm, medium inertia, 5500W servo motor
23bit optical encoder, brake
MS10